

200.64

165.00

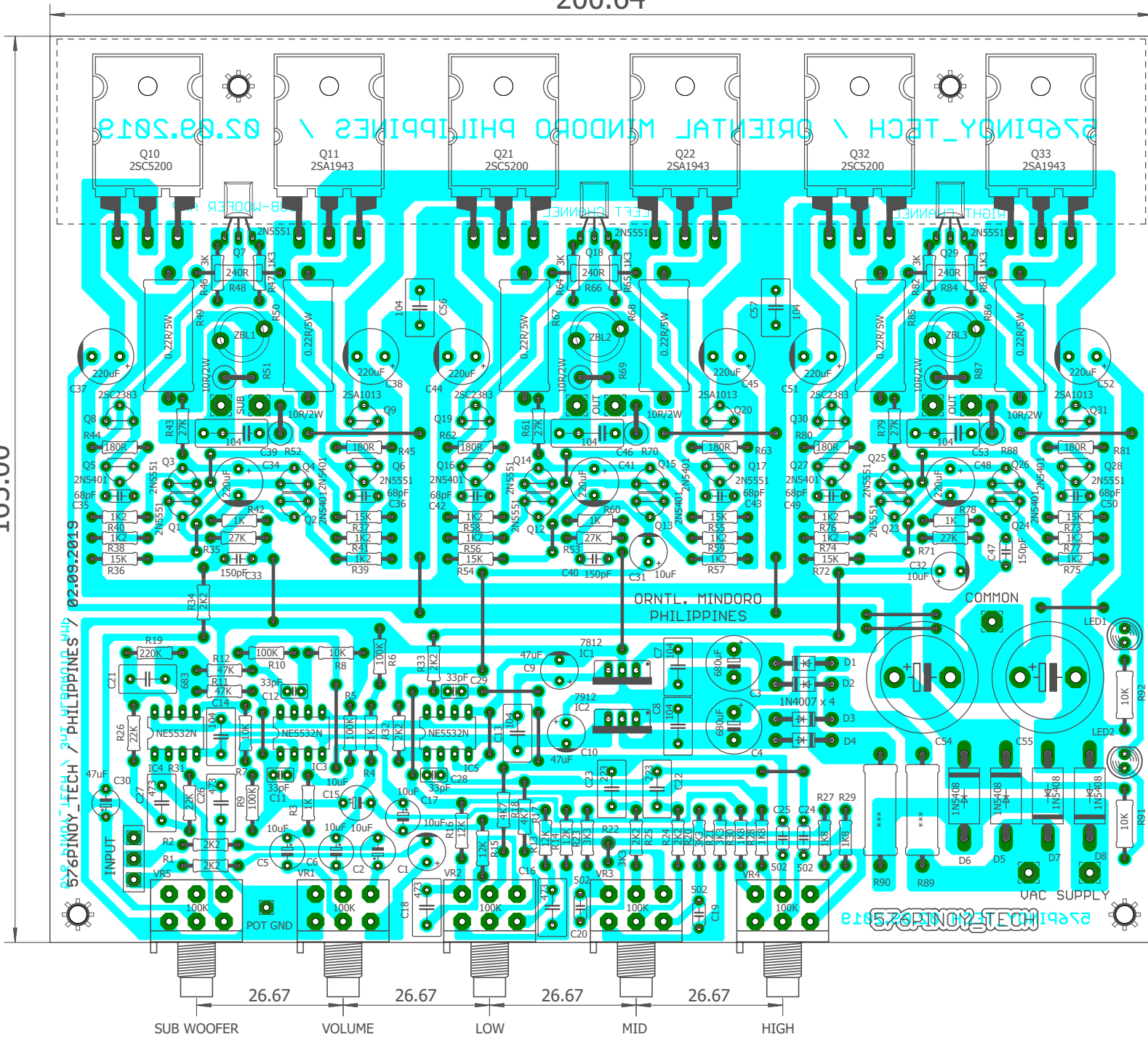

500.00

576PIN0Y_Tech / ORIENTAL MINDORO PHILIPPINES / 02.09.2019

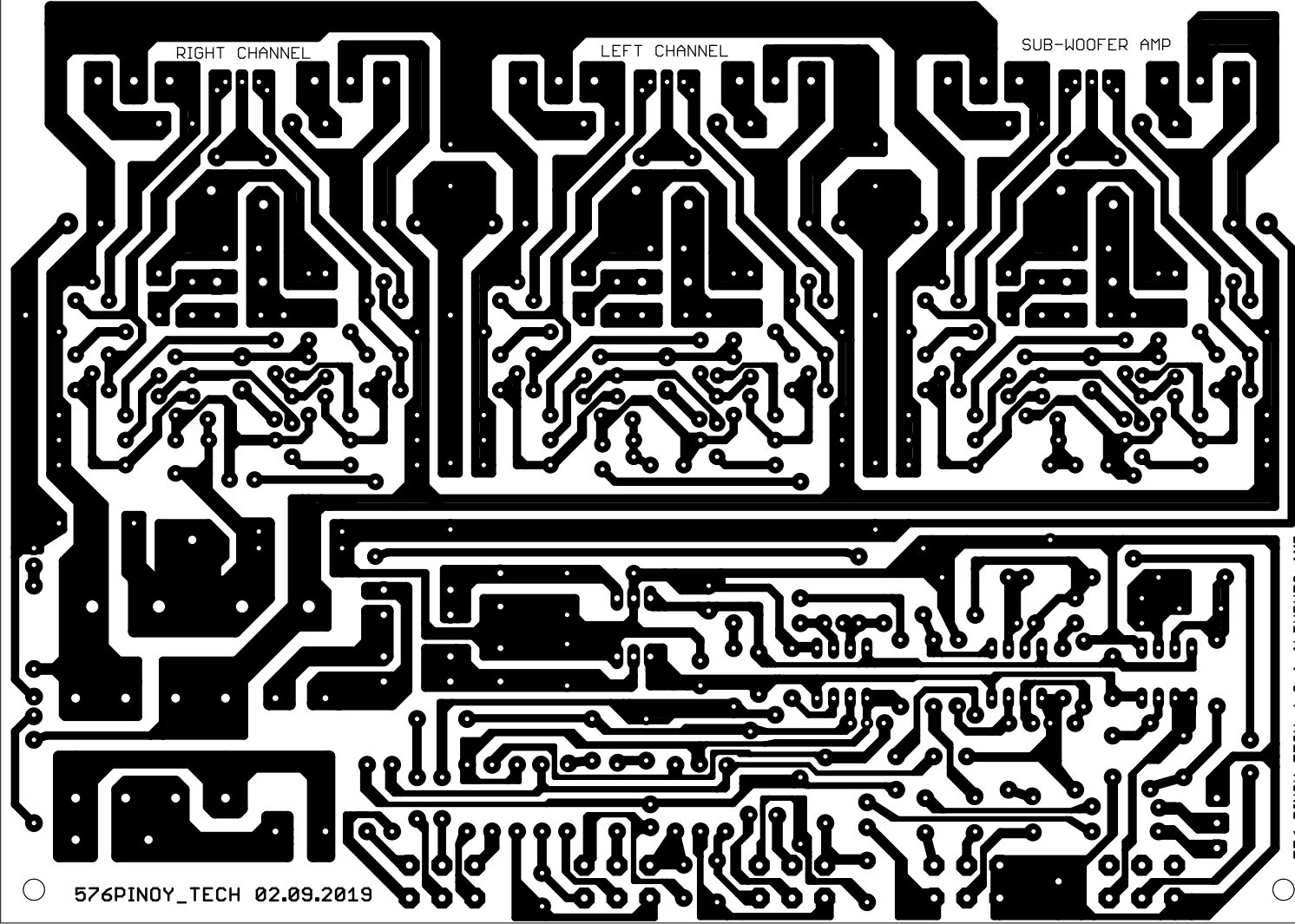

102.00

(ACR) 576PIN0Y_Tech \ 3in1 MINI ALBURUTO AMP \ FEB 09 2019

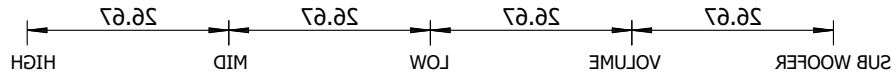

200.64

165.00

576PINOY_TECH \ ORIENTAL MINDORO PHILIPPINES \ 02.09.2019

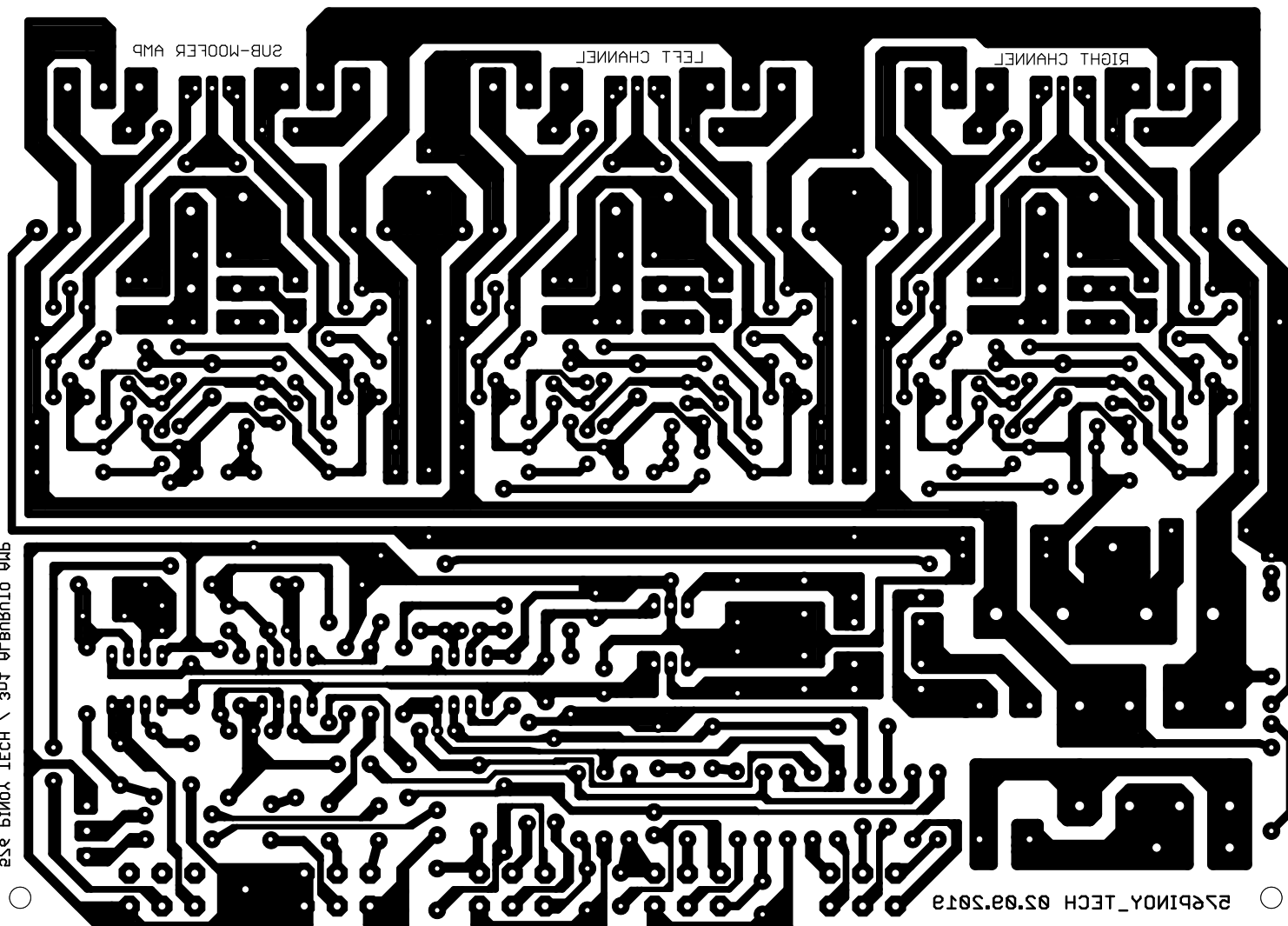

576PINOY_TECH \ 3n1 ALBURUTO AMP

576PINOY_TECH 02.09.2019



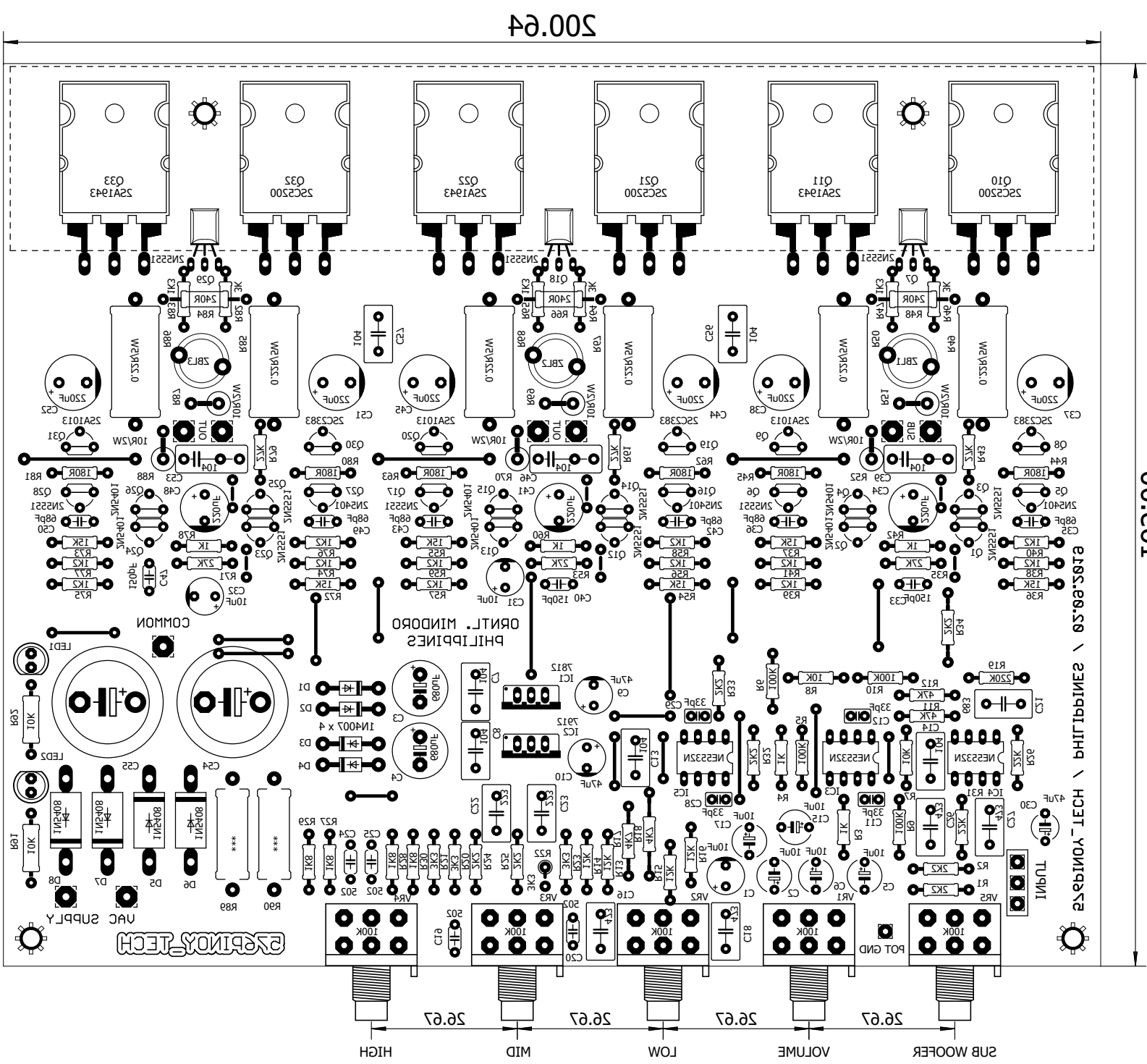

102.00

50.00

25PINOY TECH \ PHILIPPINES \ 05282024

25PINOY TECH

NAC SUPPLY

PHILIPPINES ORNLT. MINDORO

COMMON

200.64

165.00

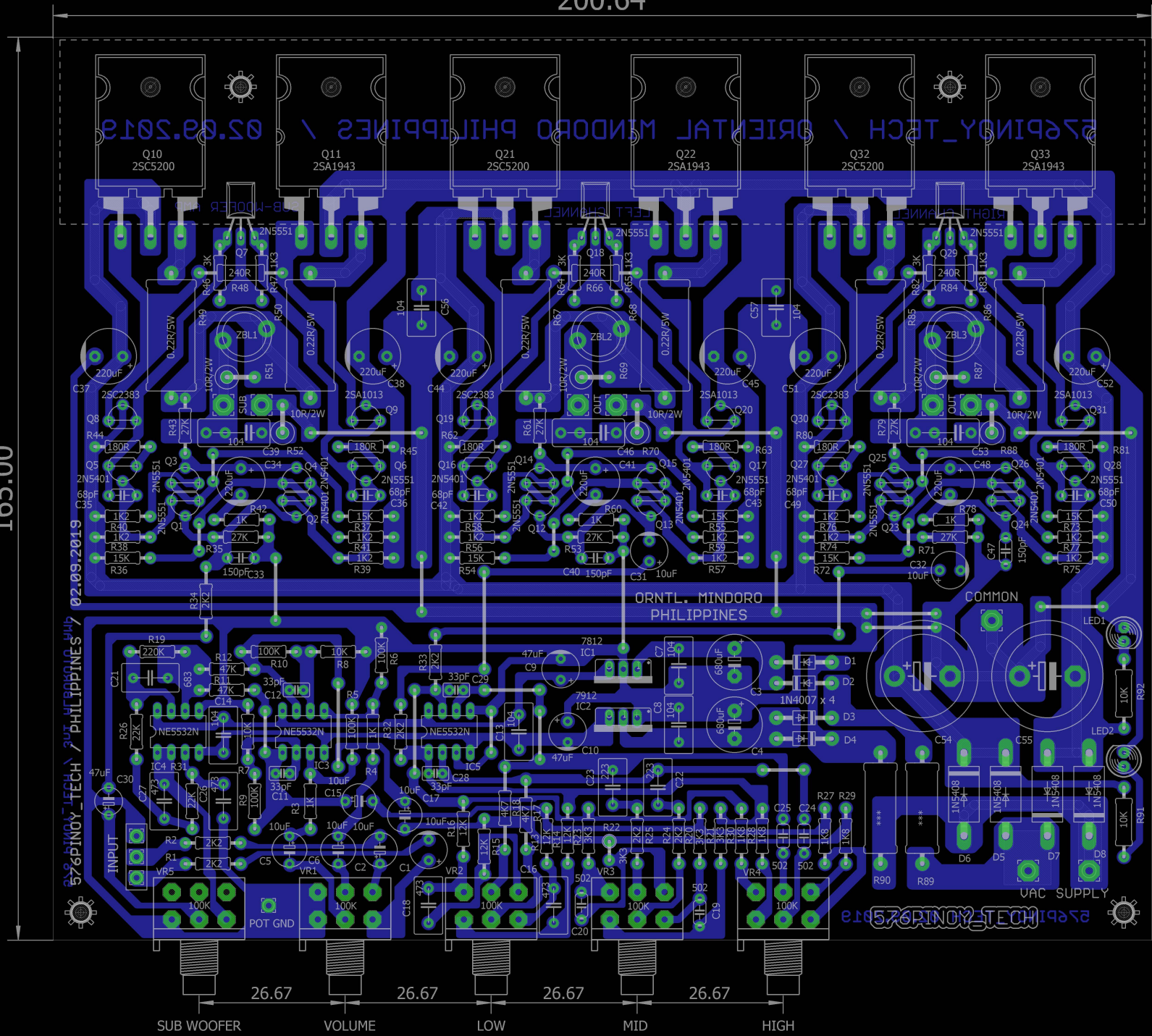

(ACR)576PINOY_TECH / 3n1 MINI ALBURUTO AMP / FEB 9, 2019

3n1 Alburuo Amp (+/-50V) / 576Pinoy_Tech / Feb 9, 2019 (page1/2)

Qty	Value	Description	Parts	Remarks
2	LED	5mm LED	LED1, LED2	
3	150pF/50V	Ceramic Cap	C33, C40, C47	
4	33pF/50V	Ceramic Cap	C11, C12, C28, C29	
6	68pF/50V	Ceramic Cap	C35, C36, C42, C43, C49, C50	
9	104/50V	Mylar Cap	C7, C8, C13, C14, C39, C46, C53, C56, C57	
2	223/50V	Mylar Cap	C22, C23	
4	473/50V	Mylar Cap	C16, C18, C26, C27	
4	502/50V	Mylar Cap	C19, C20, C24, C25	
1	683/50V	Mylar Cap	C21	
2	4700uF/50V	Electrolytic Cap	C54, C55	as high uF
8	10uF/16V	Electrolytic Cap	C1, C2, C5, C6, C15, C17, C31, C32	
3	220uF/50V	Electrolytic Cap	C34, C41, C48	
6	220uF/63V	Electrolytic Cap	C37, C38, C44, C45, C51, C52	
3	47uF/16V	Electrolytic Cap	C9, C10, C30	
2	680uF/35V	Electrolytic Cap	C3, C4	
12	2N5551	NPN Transistor	Q1, Q3, Q6, Q7, Q12, Q14, Q17, Q18, Q23, Q25, Q28, Q29	
3	2SC2383	NPN Transistor	Q8, Q19, Q30	
3	2SC5200	NPN Transistor	Q10, Q21, Q32	
9	2N5401	PNP Transistor	Q2, Q4, Q5, Q13, Q15, Q16, Q24, Q26, Q27	
3	2SA1013	PNP Transistor	Q9, Q20, Q31	
3	2SA1943	PNP Transistor	Q11, Q22, Q33	
3	NE5532N	op-amp	IC3, IC4, IC5	LM4558
3	IC Socket	8pins IC Socket		
1	LM7812	Vreg TO-220	IC1	
1	LM7912	Vreg TO-220	IC2	
4	1N5408	Rectifier Diode	D5, D6, D7, D8	
4	1N4007	Rectifier Diode	D1, D2, D3, D4	
6	180R	Resistor 1/4W	R44, R45, R62, R63, R80, R81	
5	1K	Resistor 1/4W	R3, R4, R42, R60, R78	
12	1K2	Resistor 1/4W	R38, R39, R40, R41, R56, R57, R58, R59, R74, R75, R76, R77	
3	1K3	Resistor 1/4W	R47, R65, R83	
4	1K8	Resistor 1/4W	R27, R28, R29, R30	
7	2K2	Resistor 1/4W	R1, R2, R24, R25, R32, R33, R34	
3	3K	Resistor 1/4W	R46, R64, R82	

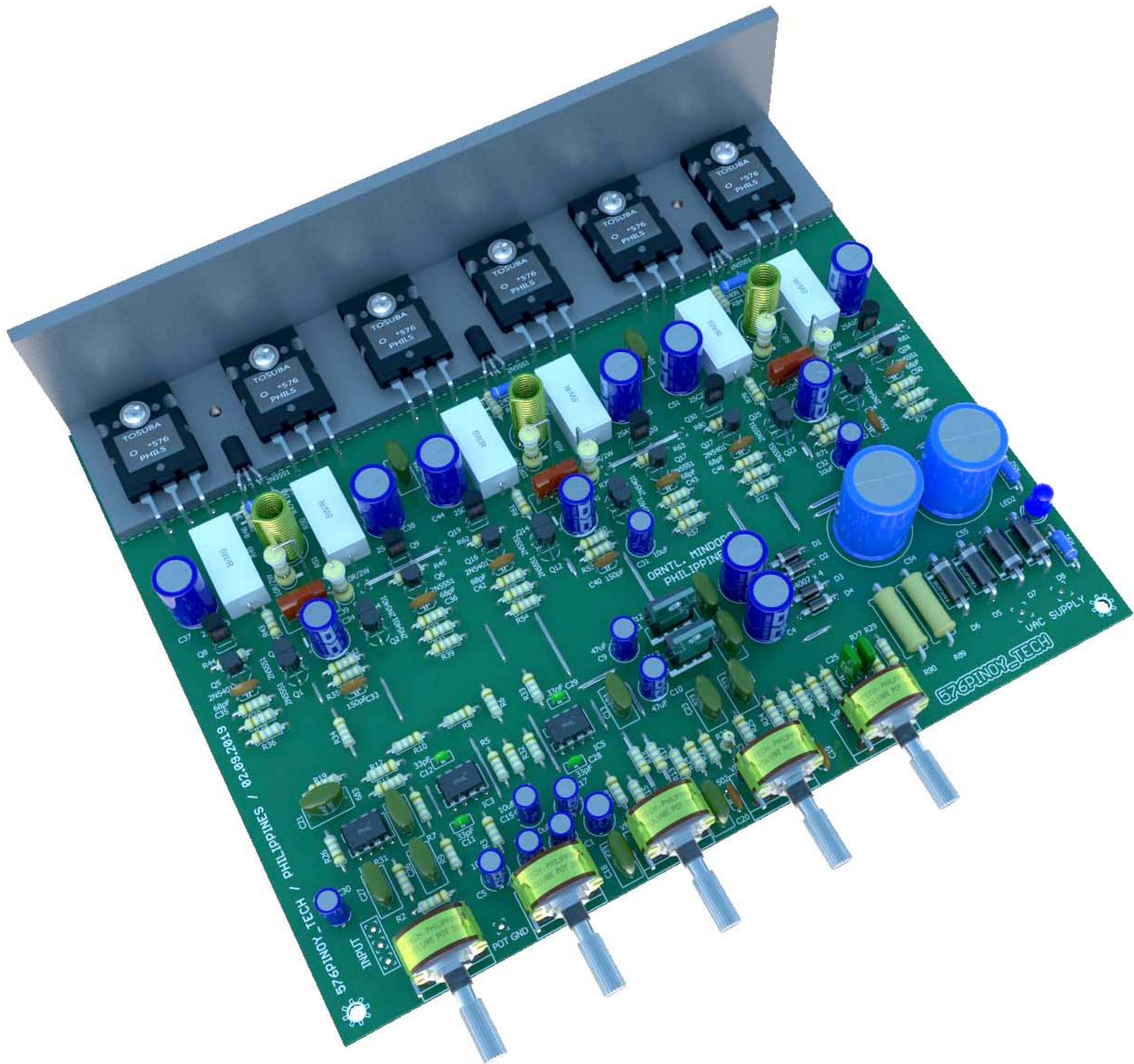

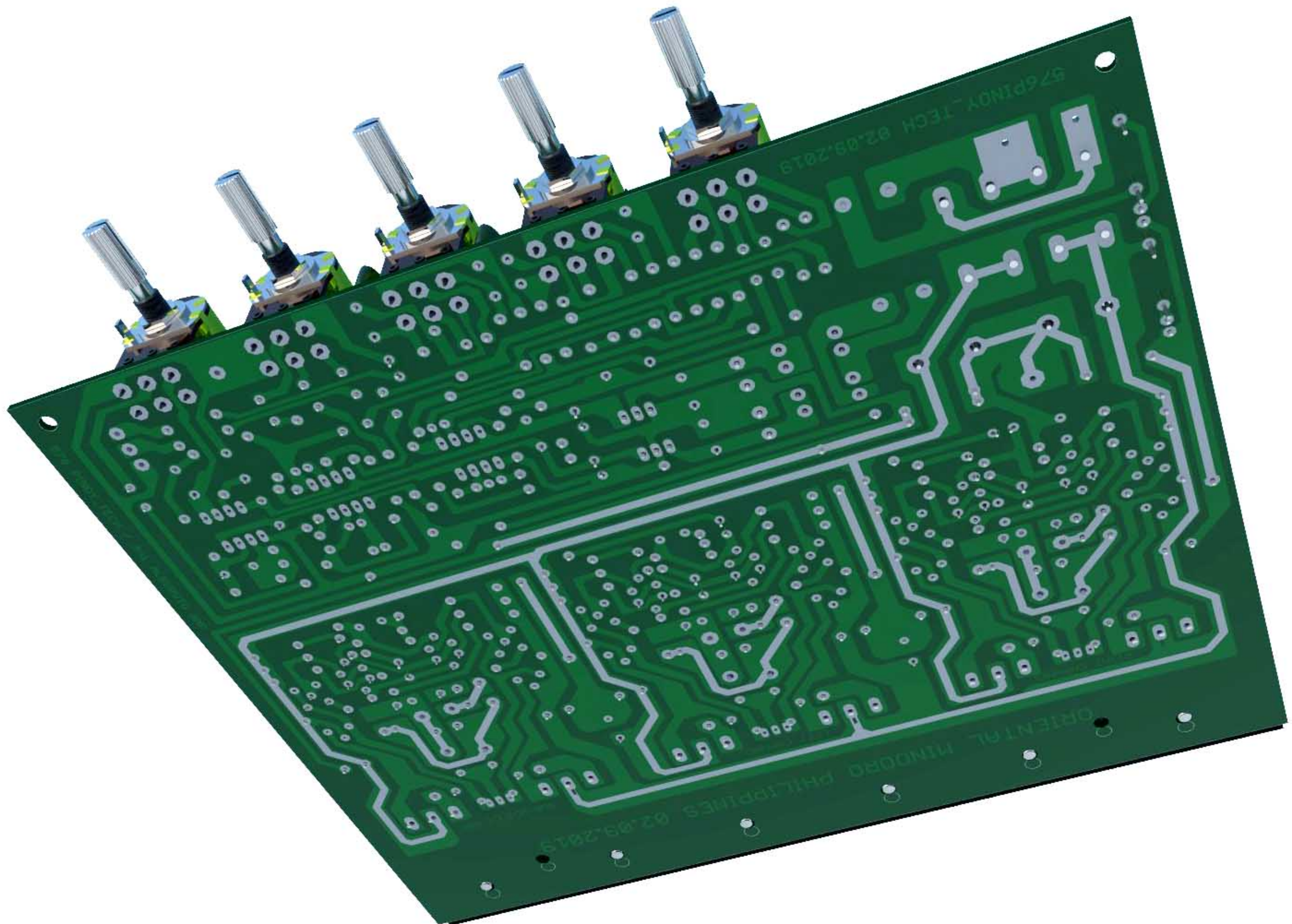

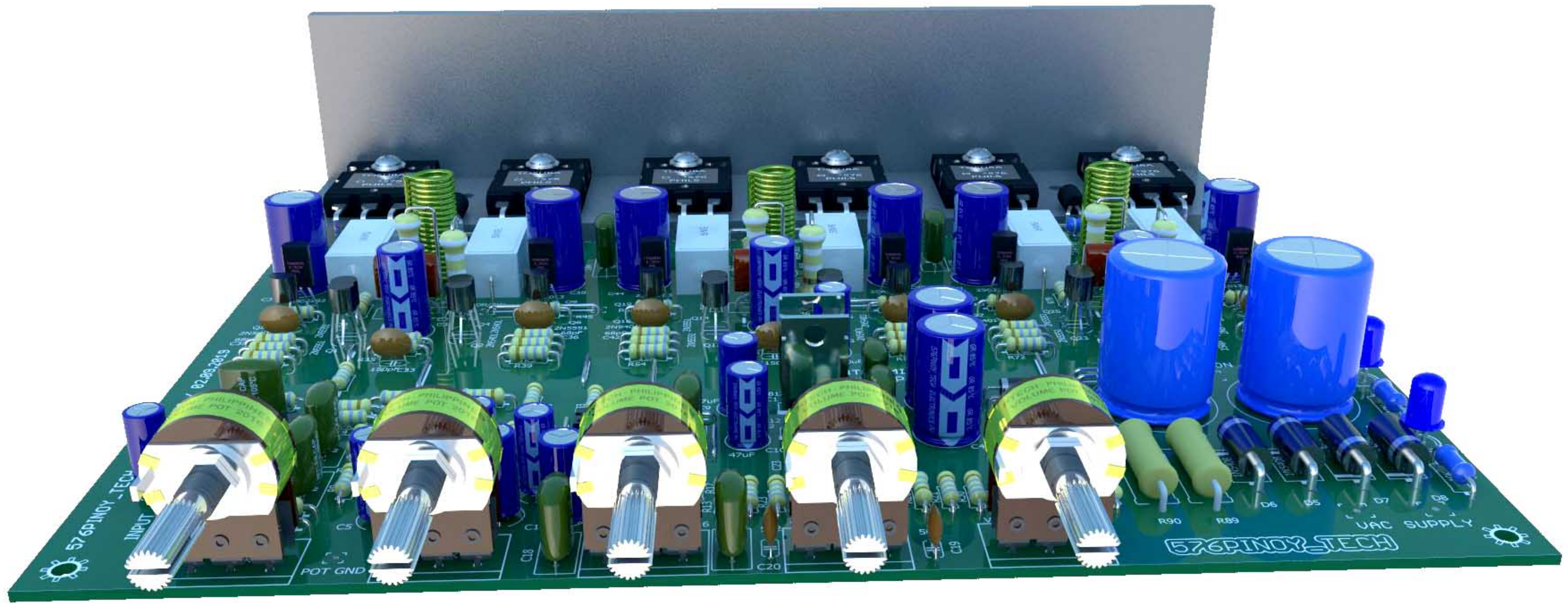

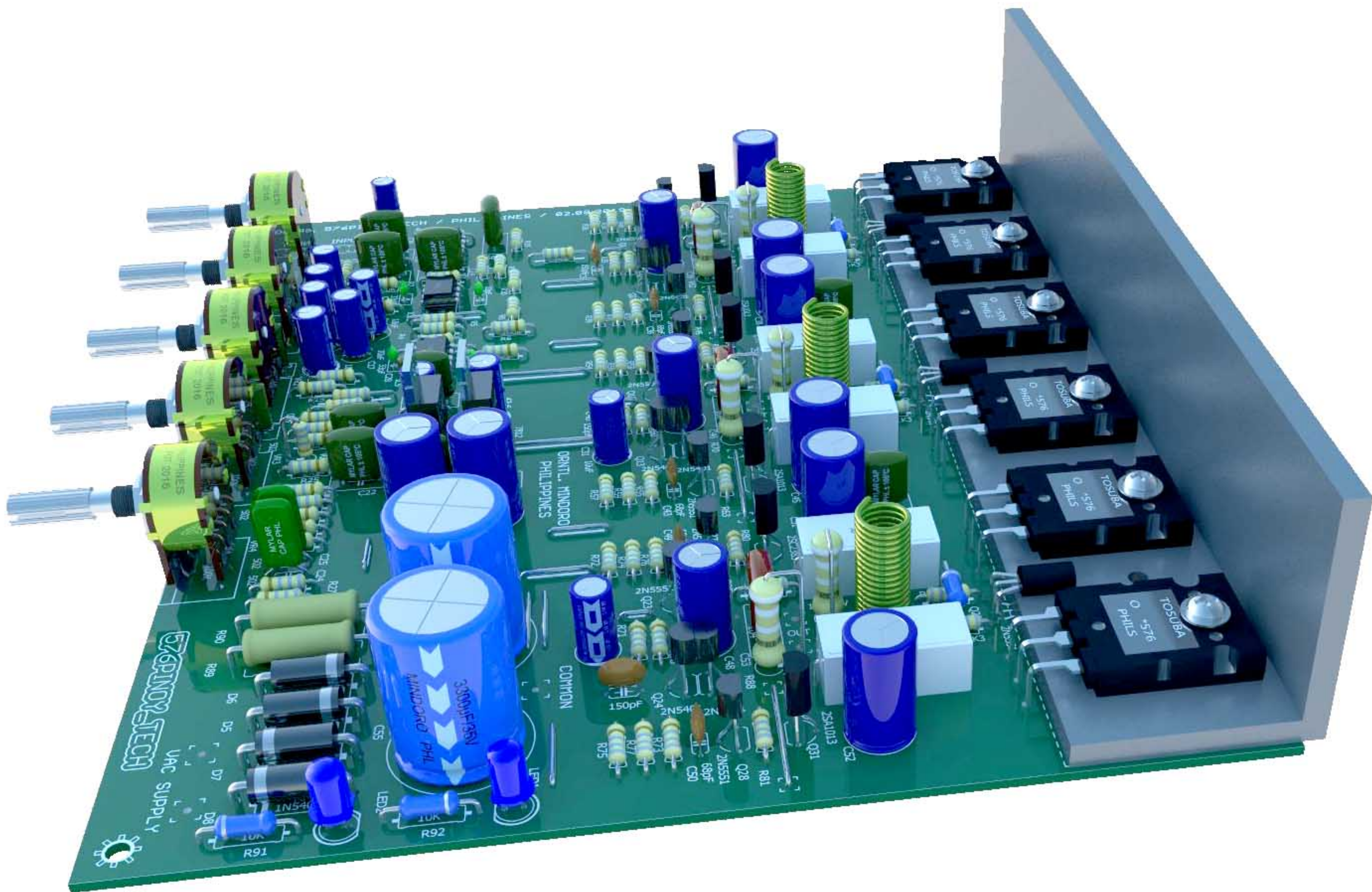

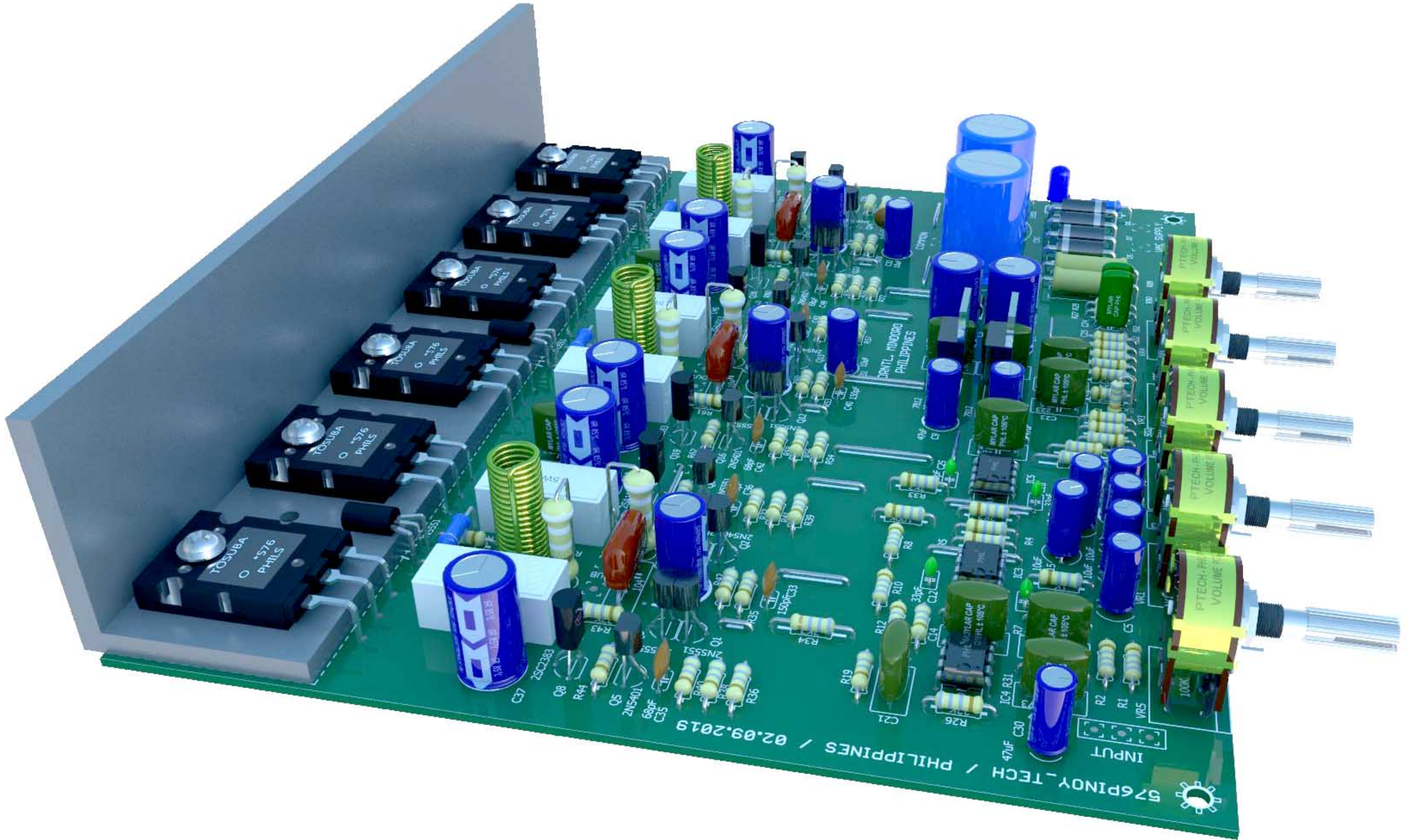

576PIN0Y_Tech / PHILIPPINES / 02.09.2019



INPUT

PTECH-PH
VOLUME

PTECH-PH
VOLUME

PTECH-PH
VOLUME

PTECH-PH
VOLUME

PTECH-PH
VOLUME

TOSHIBA
576
PHILIPS

TOSHIBA
576
PHILIPS

TOSHIBA
576
PHILIPS

TOSHIBA
576
PHILIPS

TOSHIBA
576
PHILIPS

IC4 R31

IC3 R4

IC2 R5

IC1 R6

IC0 R7

IC-1 R8

R2

R1

VR1

VR2

VR3

VR4

VR5

C5

C4

C3

C2

C1

C0

R26

R25

R24

R23

R22

R21

R19

R18

R17

R16

R15

R14

R12

R11

R10

R9

R8

R7

R4

R3

R2

R1

R0

R36

R35

R34

R33

R32

R31

R44

R43

R42

R41

R40

R39

R37

R38

R39

R40

R41

R42

R43

R44

R45

R46

R47

R48

R49

C35

C36

C37

C38

C39

C40

C41

C42

C43

C44

C45

C46

C47

C48

C49

C50

C51

C52

C53

C54

C55

C56

C57

C58

C59

C60

C61

C62

C63

C64

C65

C66

C67

C68

C69

C70

C71

C72

C73

C74

C75

C76

C77

C78

C79

C80

C81

C82

C83

C84

C85

C86

C87

C88

C89

C90

C91

C92

C93

C94

C95

C96

C97

C98

C99

C100

C101

C102

C103

C104

C105

C106

C107

C108

C109

C110

C111

C112

C113

C114

C115

C116

C117

C118

C119

C120

C121

C122

C123

C124

C125

C126

C127

C128

C129

C130

C131

C132

C133

C134

C135

C136

C137

C138

C139

C140

C141

C142

C143

C144

C145

C146

C147

C148

C149

C150

C151

C152

C153

C154

C155

C156

C157

C158

C159

C160

C161

C162

C163

C164

C165

C166

C167

C168

C169

C170

C171

C172

C173

C174

C175

C176

C177

C178

C179

C180

C181

C182

C183

C184

C185

C186

C187

C188

C189

C190

C191

C192

C193

C194

C195

C196

C197

C198

C199

C200

C201

C202

C203

C204

C205

C206

C207

C208

C209

C210

C211

C212

C213

C214

C215

C216

C217

C218

C219

C220

C221

C222

C223

C224

C225

C226

C227

C228

C229

C230

C231

C232

C233

C234

C235

C236

C237

C238

C239

C240

C241

C242

C243

C244

C245

C246

C247

C248

C249

C250

C251

C252

C253

C254

C255

C256

C257

C258

C259

C260

C261

C262

C263

C264

C265

C266

C267

C268

C269

C270

C271

C272

C273

C274

C275

C276

C277

C278

C279

C280

C281

C282

C283

C284

C285

C286

C287

C288

C289

C290

C291

C292

C293

C294

C295

C296

C297

C298

C299

C300

C301

C302

C303

C304

C305

C306

C307

C308

C309

C310

C311

C312

C313

C314

C315

C316

C317

C318

C319

C320

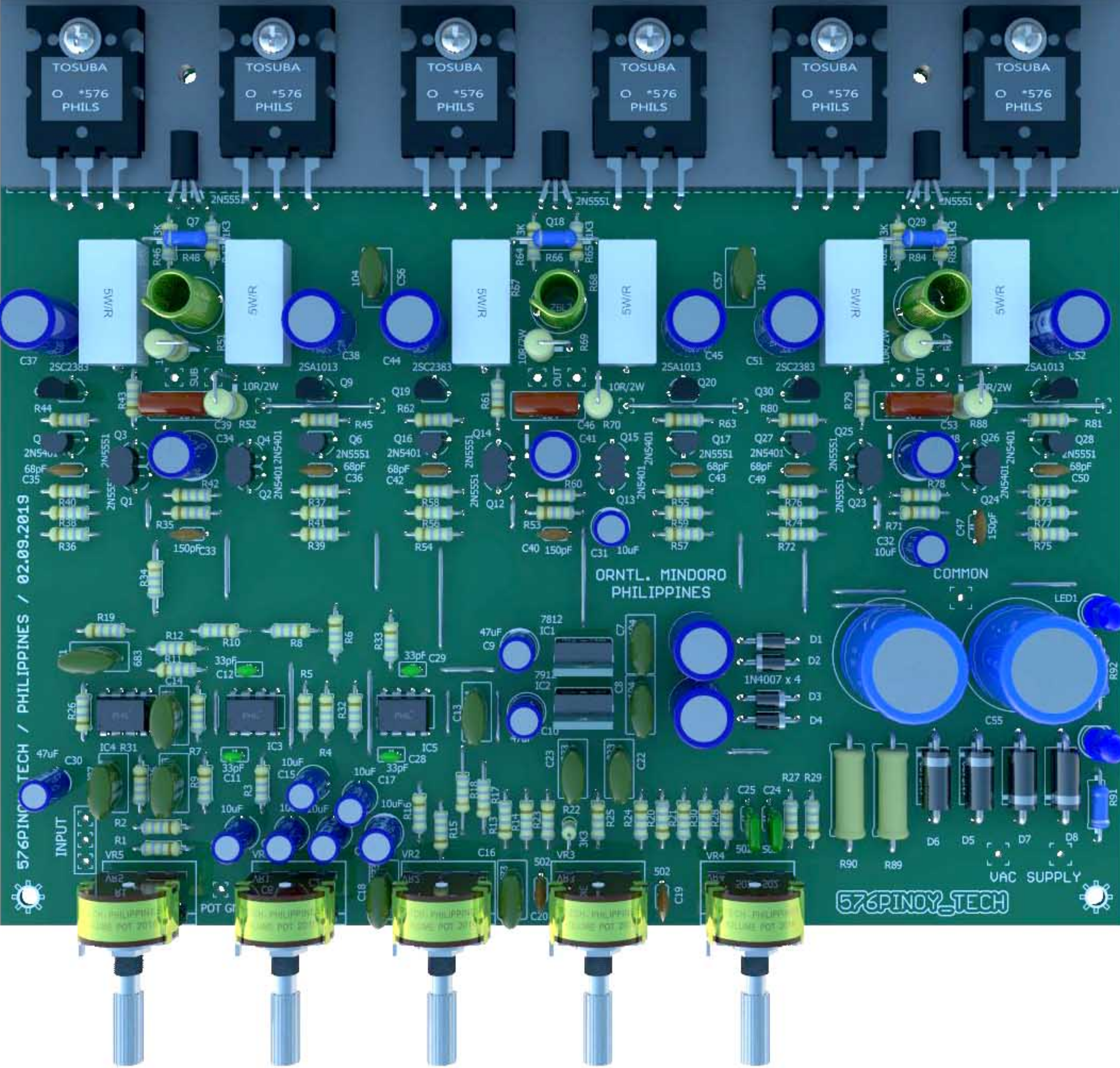

576PINOY-TECH / PHILIPPINES / 02.09.2019

ORNTL. MINDORO
PHILIPPINES

576PINOY-TECH

UAC SUPPLY

INPUT

COMMON

LED1



